

[Home Page](#)[Products](#)[Price List](#)[Links & PDFs](#)

X-RAY DETECTOR

XR-100CR

中文



**149 eV  
Resolution!**

**All solid state  
design...**

**No more liquid  
nitrogen!**

XR-100 Landed on Mars!

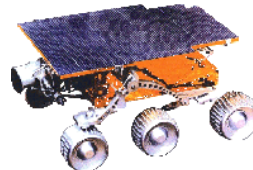

The XR-100CR is a new high performance x-ray detector, preamplifier, and cooler system using a thermoelectrically cooled Si-PIN photodiode as an x-ray detector. Also mounted on the 2-stage cooler are the input FET and a novel feedback circuit. These components are kept at approximately -55 °C, and are monitored by an internal temperature sensor. The hermetic TO-8 package of the detector has a light tight, vacuum tight thin Beryllium window to enable soft x-ray detection.

The XR-100CR represents a breakthrough in x-ray detector technology by providing "off-the-shelf" performance previously available only from expensive cryogenically cooled systems.

## Features

- Si-PIN Photodiode
- 2-Stage Thermoelectric Cooler
- Temperature Monitor
- Beryllium Window
- Multilayer Collimator
- Hermetic Package (TO-8)
- Wide Detection Range
- Easy to Operate

## Applications

- [X-Ray Fluorescence](#)
- [RoHS/WEEE](#)
- Portable Instruments
- [OEM](#)
- Nuclear Medicine
- Teaching and Research
- [Art and Archaeology](#)
- [Process Control](#)
- [Mössbauer Spectrometers](#)
- Space and Astronomy
- Environmental Monitoring
- Nuclear Plant Monitoring
- Toxic Dump Site Monitoring
- PIXE

## Additional Information

- [Selection Guide](#)
- [Additional Performance Spectra and Detector Properties](#)
- [Application Spectra](#)
- [Si-PIN vs. CdTe](#)
- [Mechanical Dimensions](#)
- [Multilayer Collimator](#)
- [OEM & Custom Applications](#)

## Accessories

- [MP1 XRF Mounting Plate](#)
- [Vacuum Applications](#)
- [Collimator Kit \(high flux applications\)](#)
- [Experimenter's XRF Kit](#)

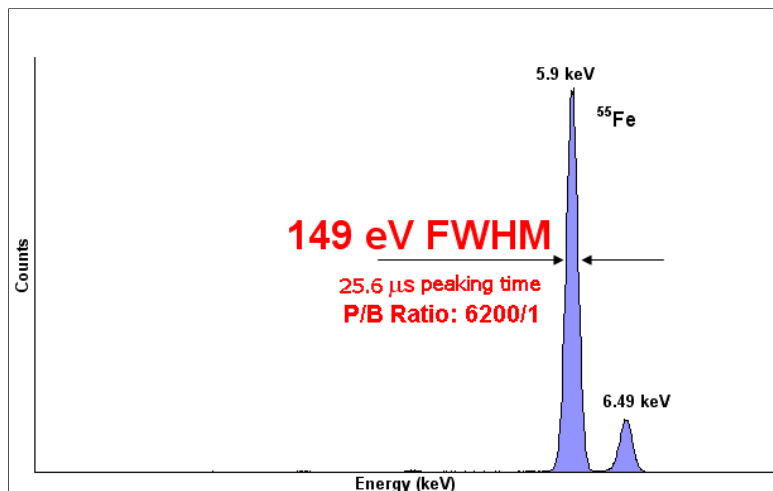
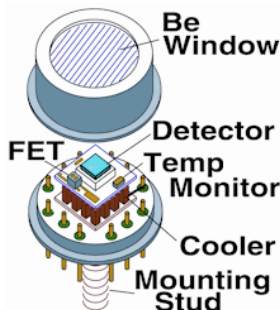

Figure 1.  $^{55}\text{Fe}$  Spectrum taken with a 6 mm<sup>2</sup>/500 μm detector.

The resolution for the the 5.9 keV peak of  $^{55}\text{Fe}$  is 145 eV FWHM to 230 eV FWHM depending on detector type and shaping time constant. See [Selection Guide](#).

## Theory of Operation

X-rays interact with silicon atoms to create an average of one electron/hole pair for every 3.62 eV of energy lost in the silicon. Depending on the energy of the incoming radiation, this loss is dominated by either the Photoelectric Effect or Compton scattering. The probability or efficiency of the detector to "stop" an x-ray and create electron/hole pairs increases with the thickness of the silicon. [See efficiency curves.](#)

In order to facilitate the electron/hole collection process, a 100-200 volt bias voltage is applied across the silicon depending on the detector thickness. This voltage is too high for operation at room temperature, as it will cause excessive leakage, and eventually breakdown. Since the detector in the XR-100CR is cooled, the leakage current is reduced considerably, thus permitting the high bias voltage. This higher voltage decreases the capacitance of the detector, which lowers system noise.

The thermoelectric cooler cools both the silicon detector and the input FET transistor to the charge sensitive preamplifier. Cooling the FET reduces its leakage current and increases the transconductance, both of which reduce the electronic noise of the system.

Since optical reset is not practical when the detector is a photodiode, the XR-100CR incorporates a novel feedback method for the reset to the charge sensitive preamplifier. The reset transistor, which is typically used in most other systems has been eliminated. Instead, the reset is done through the high voltage connection to the detector by injecting a precise charge pulse through the detector capacitance to the input FET. This method eliminates the noise contribution of the reset transistor and further improves the energy resolution of the system.

A temperature monitor diode chip is mounted on the cooled substrate to provide a direct reading of the temperature of the internal components, which will vary with room temperature. Below -20 °C, the performance of the XR-100CR will not change with a temperature variation of a few degrees. Hence, closed loop temperature control is not necessary when using the XR-100CR at normal room temperature. For OEM applications or hand held XRF instrumentation a closed loop temperature control is recommended. The Active Temperature Control is optional in the PX2CR and standard in the PX4.

## XR100-CR Specifications

General	
Detector Type	Si-PIN
Detector Size	From 6 mm <sup>2</sup> to 25 mm <sup>2</sup> , <a href="#">See Selection Guide</a>
Silicon Thickness	300 μm and 500 μm <a href="#">See efficiency curves</a>
Collimator	Multilayer, <a href="#">click here for more information</a>
Energy Resolution @ 5.9 keV ( <sup>55</sup> Fe)	145 eV FWHM to 230 eV FWHM depending on detector type and shaping time constant. <a href="#">See Selection Guide</a>
Background Counts	<3 x 10 <sup>-3</sup> /s, 2 keV to 150 keV for 7 mm <sup>2</sup> /300 μm detector
Detector Be Window Thickness	1 mil (25 μm), or 0.5 mil (12.5 μm), <a href="#">See transmission curves</a>
Charge Sensitive Preamplifier	Amptek custom design with reset through the H.V. connection
Gain Stability	<20 ppm/°C (typical)
Case Size	3.00 x 1.75 x 1.13 in (7.6 x 4.4 x 2.9 cm), <a href="#">See mechanical dimensions</a>
Weight	4.9 ounces (139 g)
Total Power	<1 Watt
Warranty Period	1 Year
Typical Device Lifetime	5 to 10 years, depending on use
Operation conditions	0°C to +40°C
Storage and Shipping	Long term storage: 10+ years in dry environment Typical Storage and Shipping: -20°C to +50°C, 10 to 90% humidity non condensing
	TUV Certification Certificate #: CU 72072412 01 Tested to: UL 61010-1: 2004 R7 .05 CAN/CSA-C22.2 61010-1: 2004
Inputs	
Preamplifier Power	±8 to 9 V @ 15 mA with no more than 50 mV peak-to-peak noise
Detector Power	+100 to 200 V @ 1 μA (varies for different detector types) very stable <0.1% variation
Cooler Power	Current = 350 mA maximum, voltage = 4 V maximum with <100 mV peak-to-peak noise Note: the XR-100CR includes its own temperature controller
Outputs	
Reset Output Waveform	The output of the XR100CR swings from +5 V to -5 V. The reset period will vary with detector type and count rate.

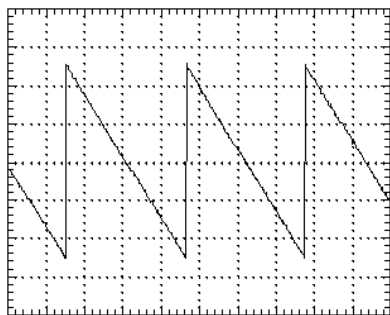
	
Preamplifier Sensitivity	1 mV/keV typical (may vary for different detectors)
Preamplifier Polarity	Negative signal output (1 kohm maximum load)
Preamplifier Feedback	Reset through the detector capacitance
Temperature Monitor Sensitivity	PX2CR: 770 mV = -50 °C PX4: direct reading in K through software.

**XR-100CR Connectors**

Preamp Output	BNC coaxial connector
Power and Signal	6-Pin LEMO connector (Part# ERA.1S.306.CLL)
Interconnect Cable	XR100CR to PX2CR: 6-Pin LEMO (Part# FFA.1S.306.CLAC57) to 9-Pin D (5 ft length) XR100CR to PX4: 6-Pin LEMO (Part# FFA.1S.306.CLAC57) to 6-Pin LEMO (5 ft length)

**6-Pin LEMO Connector Pin Out**

Pin 1	Temperature monitor diode
Pin 2	+H.V. Detector Bias, +100 - 200 V maximum
Pin 3	-9 V Preamp power
Pin 4	+9 V Preamp power
Pin 5	Cooler power return
Pin 6	Cooler power 0 to +4 V @ 350 mA
Case	Ground and shield

**Options**

- Other Beryllium window thicknesses are available on special order (0.3 mil - 7.5 μm).
- [Collimator Kit](#) for high flux applications.
- [Vacuum Accessories](#)
- [OEM Applications](#)
- [X-123 Configuration](#)



Figure 2a. The X-123 configuration, which includes the detector, preamplifier, digital processor, and power supplies all in one box.



Figure 2b. The detector/preamplifier is available in OEM configurations to fit the requirements of any system. Pictured is the detector with the PA-230 preamplifier and housing. [See the OEM page for details.](#)



Figure 3. XR100CR Detector Extender Options.

### Power Supply and Shaping Amplifier Options for the XR-100CR

Power to the XR-100CR is provided by either the [PX4](#) or the [PX2CR](#):

- A) The PX4 is DC powered by an AC adaptor and provides both a variable Digital Pulse Shaping Amplifier (0.330  $\mu$ s to 45  $\mu$ s shaping time) and the MCA function.
- B) The PX2CR is AC powered and also includes a spectroscopy grade Analog Shaping Amplifier with fixed shaping time constant (6  $\mu$ s, 12  $\mu$ s or 20  $\mu$ s). The output of the PX2CR must then go to an external MCA such as the [MCA8000A](#).

The XR-100CR/PX2CR or XR-100CR/PX4 systems ensures stable operation in less than one minute from power turn-on.

#### Option A: High Performance PX4 with Digital Pulse Shaping

The [PX4 Digital Pulse Processor, MCA, and Power Supply](#) for the XR-100CR is DC powered by an AC adaptor. It provides a variable Digital Shaping Amplifier (0.330  $\mu$ s to 45  $\mu$ s shaping time), the MCA function, and all necessary power supplies for the XR-100CR.

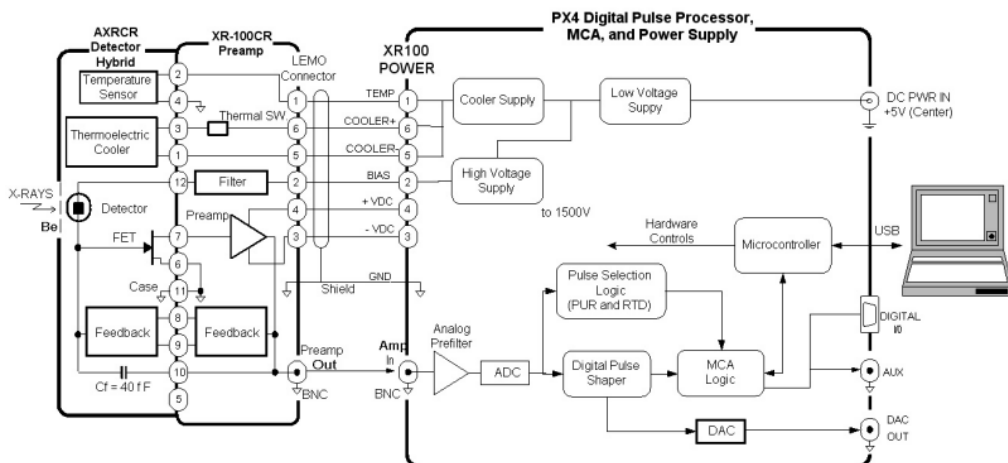

Figure 4. This diagram shows the internal connections between the AXRCR hybrid sensor and the electronics within the case, as well as the external connections to the PX4.

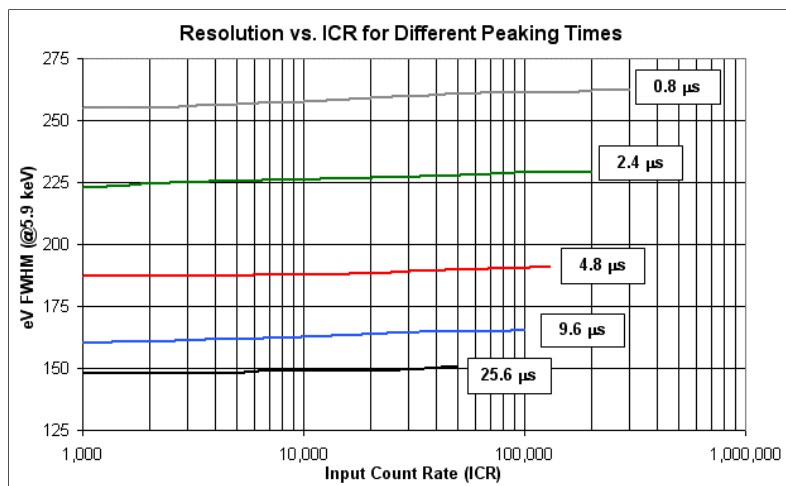

Figure 5. Resolution vs. input count rate (ICR) for various peaking times. Taken with XR100CR and PX4.

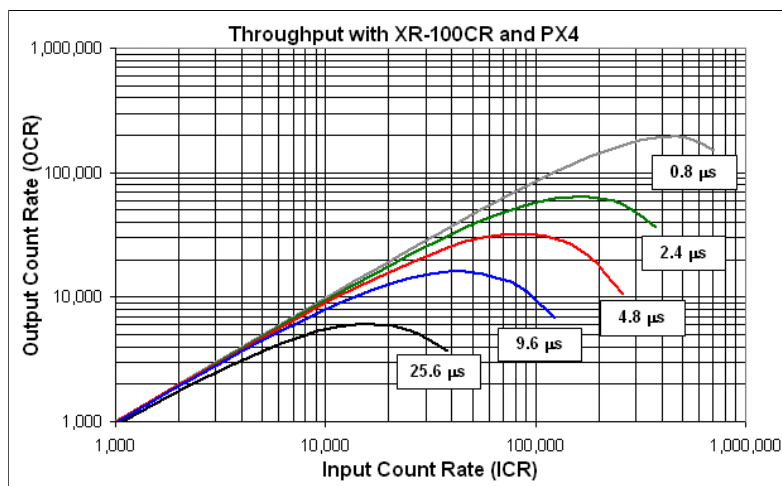

Figure 6. Throughput for various peaking times. Taken with XR100CR and PX4.

### Option B: PX2 with Analog Pulse Shaping

The [PX2 Shaping Amplifier and Power Supply](#) for the XR-100CR is AC powered. It includes a spectroscopy grade shaping amplifier with a fixed shaping time constant (6  $\mu$ s, 12  $\mu$ s or 20  $\mu$ s) and all the necessary power supplies for the XR-100CR. The output of the PX2CR must then go to an external MCA such as the [MCA8000A](#).

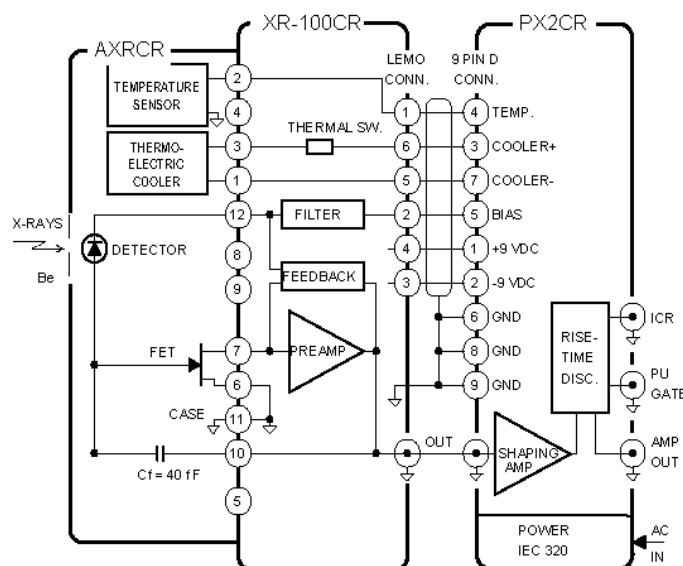

Figure 7. This diagram shows the internal connections between the AXRCR hybrid sensor and the electronics within the case, as well as the external connections to the PX2CR.

## Use of Collimators

Most of Amptek's detectors contain internal collimators to improve spectral quality. X-rays interacting near the edges of the active volume of the detector may produce small pulses due to partial charge collection. These pulses result in artifacts in the spectrum which, for some applications, obscure the signal of interest. The internal collimator restricts X-rays to the active volume, where clean signals are produced. Depending on the type of detector, collimators can

- improve peak to background (P/B)
- eliminate edge effects
- eliminate false peaks

[Click here for more information.](#)

## Vacuum Operation

The XR-100CR can be operated in air or in vacuum down to  $10^{-8}$  Torr. There are two ways the XR-100CR can be operated in vacuum: 1) The entire XR-100CR detector and preamplifier box can be placed inside the chamber. In order to avoid overheating and dissipate the 1 Watt of power needed to operate the XR-100CR, good heat conduction to the chamber walls should be provided by using the four mounting holes. An optional Model 9DVF 9-Pin D vacuum feedthrough connector on a Conflat is available to connect the XR-100CR to the PX2CR or PX4 outside the vacuum chamber. 2) The XR-100CR can be located outside the vacuum chamber to detect X-Rays inside the chamber through a standard Conflat compression O-ring port. Optional Model EXV9 (9 inch) vacuum detector extender is available for this application. [Click here for more information on vacuum applications and options.](#)

## Efficiency Curves

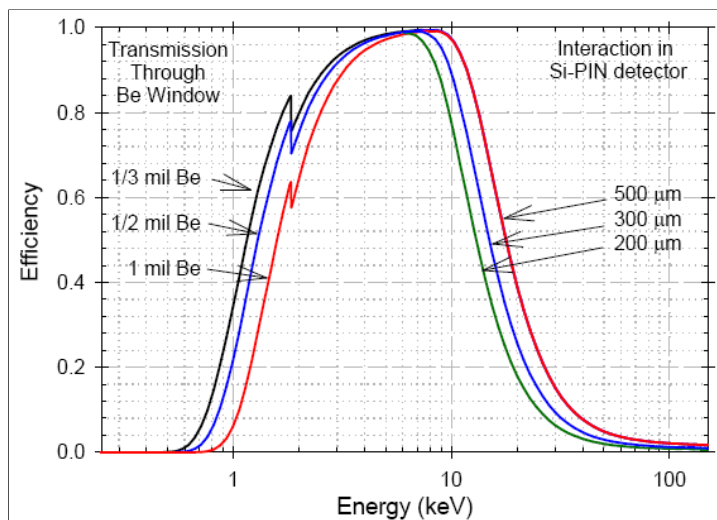

Figure 8 (linear). Shows the intrinsic full energy detection efficiency for the XR-100CR detectors. This efficiency corresponds to the probability that an X-ray will enter the front of the detector and deposit all of its energy inside the detector via the photoelectric effect.

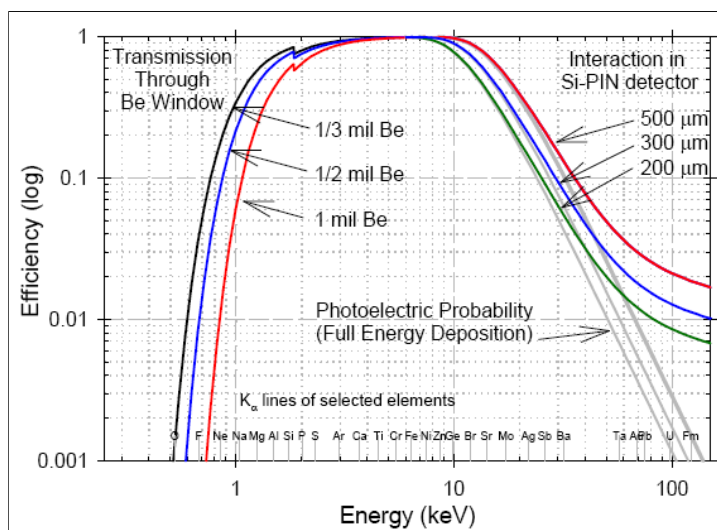

Figure 9 (log). Shows the probability of a photon undergoing any interaction, along with the probability of a photoelectric interaction which results in total energy deposition. As shown, the photoelectric effect is dominant at low energies but at higher energies above about 40 keV the photons undergo Compton scattering, depositing less than the full energy in the detector.

Both figures above combine the effects of transmission through the Beryllium window (including the protective coating), and interaction in the silicon detector. The low energy portion of the curves is dominated by the thickness of the Beryllium window, while the high energy portion is dominated by the thickness of the active depth of the Si detector. Depending on the window chosen, 90% of the incident photons reach the detector at energies ranging from 2 to 3 keV. Depending on the detector chosen, 90% of the photons are detected at energies up to 9 to 12 keV.

[Efficiency Package](#): A ZIP file of coefficients and a FAQ about efficiency. This package is provided for general information. It should not be used as a basis for critical quantitative analysis.

## XR-100 Lands on Mars on the Pathfinder Mission!

For its unique design and reliability, this detector was selected for the Pathfinder Mission to perform rock and soil analysis using x-ray fluorescence techniques.

**Here is the first rock spectrum from Mars!**

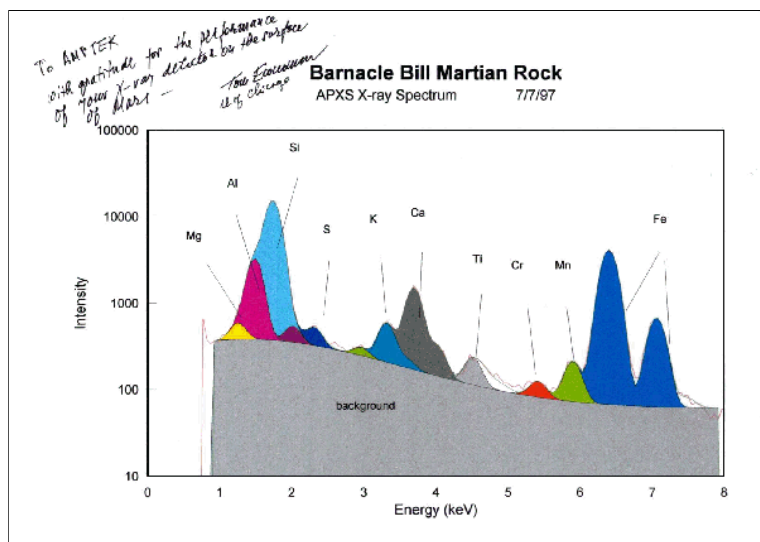

Figure 10. Courtesy of the University of Chicago.

## Complete XRF System

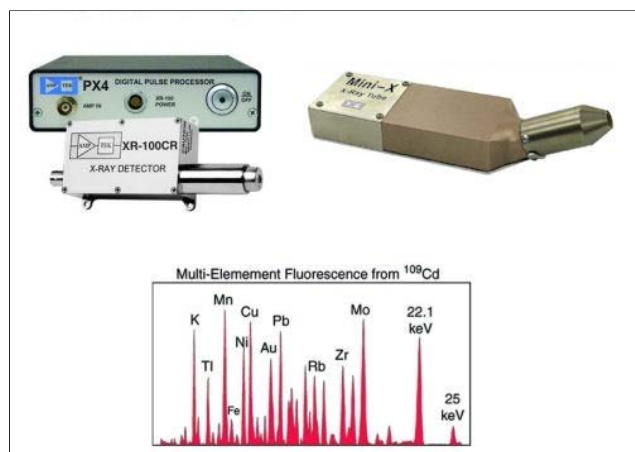

Figure 11. Complete XRF system.

### Complete XRF System Includes

- XR-100CR X-Ray Detector
- [PX4](#) Digital Pulse Processor, MCA, and Power Supply
- [Mini-X](#) USB Controlled X-Ray Tube
- [XRF-FP](#) Quantitative Analysis Software
- [MP1](#) XRF Mounting Plate



Figure 12. XR-100CR and Mini-X in typical XRF configuration.

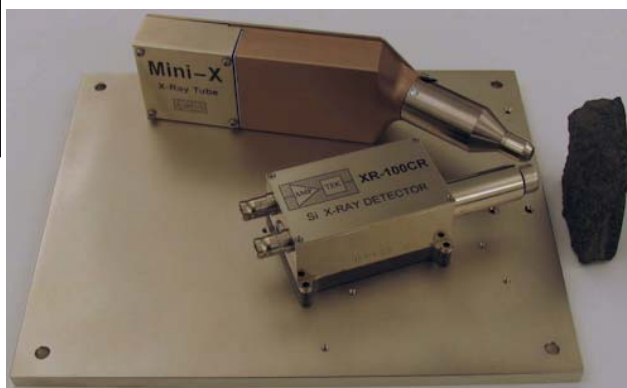

Figure 13. XR100CR and Mini-X on the MP1 XRF mounting plate.

See the [Experimenter's XRF Kit](#).

## Additional Information

- [Selection Guide](#)
- [Additional Performance Spectra and Detector Properties](#)
- [Si-PIN vs. CdTe](#)
- [Mechanical Dimensions](#)
- [Multilayer Collimator](#)
- [Efficiency Package \(zip file\)](#)
- [OEM & Custom Applications](#)

## Accessories

- [MP1 XRF Mounting Plate](#)
- [Vacuum Applications](#)
- [Collimator Kit \(high flux applications\)](#)
- [Experimenter's XRF Kit](#)

[XR-100CR Specifications in PDF \(382k\)](#)

## Application Notes, Tutorials and Resources

- [Application Spectra](#)
- [Art and Archaeology](#)
- [X-Ray Fluorescence - A Description](#)
- [X-Ray Emission Line Chart](#)
- [Glossary](#)
- [Publications](#)
- [History of XR100 Resolution](#)
- [Digital Pulse Processor FAQ](#)

---

[Home Page](#) | [Products](#) | [Price list](#) | [Company Profile](#) | [Press Release](#)

Revised July 13, 2010